

**Part Number:** 115174

**Part Description:** Compressed Natural Gas (CNG) Fuel Storage Cylinder



## Product Technical Specifications

### General Specifications

Internal Volume .....	100.6 ±1.8 Gallons (381 ±7 L)
Overall Length @ 350 psi .....	86.1" ±0.2 (2187 ±5mm)
Overall Length @ 3600 psi .....	86.4" ±0.2 (2194 ±5mm)
Cylinder Length .....	79.6" ±0.2 (2023 ±5mm)
Minimum Saddle Width @ 3600 psi .....	82.0" ±0.2 (2083 ±5mm)
Cylinder Centerline to Sidewall Depth .....	10.8" ±0.1 (275 ±2mm)
Overall Diameter @ 350 psi .....	21.3" ±0.2 (540 ±7mm)
Cylinder Mass .....	184 ±12 lb (84 ±5 kg)
Approved Mount Style (Horizontal) .....	Collar Mount (or Bracket Mount)
Approved Service Gas .....	Compressed Natural Gas (CNG)
Service Life .....	20 Years
Cylinder Construction .....	Type IV
Cylinder Certifications (115174) .....	NGV2-2007
.....	CSA B51-14, Part 2
Service Pressure .....	3,600 psi (24.8 MPa) @ 70°F (21°C)
Minimum Working Pressure .....	290 psi (2 MPa)
Cylinder Temperature Range .....	-40°F (-40°C) to 185°F (85°C)
Color .....	Black

For Gasoline Gallon Equivalent (GGE), Diesel Gallon Equivalent (DGE), and Standard Cubic Feet (SCF) information for this cylinder refer to the *Quantum CNG Cylinder General Specifications* document.

Refer to Page 4 for cylinder mounting specifications.

## Approved Valves and Pressure Relief Devices (PRD)

 **DANGER**

*Only approved valves and PRD's are to be installed in your Quantum cylinder. Installation of a valve, PRD or combination of the two components not approved for your cylinder will result in death or serious injury.*

### Manual Valves:

1. Quantum PN 114816, Use with PRD #1, #2, and #3

### Automatic Valves:

1. N/A

### PRD's:

1. Quantum PN 115342 Manifold Assembly, Use with Manual Valve #1 indicated above.
2. Quantum PN 115791 Manifold Assembly, Use with Manual Valve #1 indicated above.
3. Quantum PN 115855 Manifold Assembly, Use with Manual Valve #1 indicated above.

 **DANGER**

*The PRD manifold assemblies indicated above MUST be built and installed using the specifications and criteria defined on the PRD manifold assembly data sheet for the cylinder and valve combination being used. The PRD manifold assembly MUST be properly secured, if the PRD manifold is not secured the PRD manifold assembly may not operate as intended during a PRD event. Failure of the PRD manifold to operate as intended will result in death or serious injury.*

## Mechanical Interface

Valve Interface .....	1 1/8" -12 UNF-2B
Valve / Fixed Collar Material .....	Anodized Aluminum
Fixed Side Thread Cut .....	M56 x 2 Thread
Slip Collar Material .....	Anodized Aluminum
Slip Collar Bearing (Recommended) .....	Delrin
Second Valve Interface (if applicable) .....	N/A

## Torque Specifications

Valve Interface (Recommended) .....	100 Ft.lb. (135 N.m)
Second Valve Interface (if applicable) .....	N/A

## Maintenance Parts

Valve Interface O-Ring .....	Quantum PN 111409-216
PRD (115342 PRD Manifold) .....	Quantum PN 115467-007
PRD (115791 PRD Manifold) .....	Quantum PN 114405
PRD (115855 PRD Manifold) .....	Quantum PN 115857
Replacement Certification Label - Dynamic .....	Contact Quantum Technologies
Replacement Certification Label - Static .....	Quantum PN 113446
Replacement Warning Label .....	Quantum PN 113224

## Cylinder Brackets

Some jurisdictions require that cylinder manufacturer approved cylinder brackets be used for installation of cylinders. Use only cylinder brackets produced or approved by Quantum Technologies for mounting your CNG.

*Collar Mounting* - Quantum does not manufacture and has not approved any mounting brackets for collar mounted cylinders. The mounting specifications defined in this document are predicated on the use of the mounting bracket adaptor built to meet the specifications in the drawings provided in [Appendix A – Drawings](#). Quantum is not liable for mounting bracket adaptors that are not compliant to the drawings.

*Bracket Mounting* – Use only cylinder brackets produced or approved by Quantum Technologies for mounting your CNG cylinder.

Selection and use of cylinder brackets is the sole responsibility of the installer to ensure the bracket selected will comply with all regulations applicable in the jurisdiction where the vehicle will be operated.

## Maintenance Considerations

Inspect the CNG cylinder and brackets every 3 years or 36,000 miles (60,000 km), whichever comes first. The frequency and level of inspection may vary based on state and local requirements.

For additional information, refer to the *Type IV Compressed Natural Gas (CNG) Cylinder Installation and Maintenance Guide* available at [www.qtw.com](http://www.qtw.com).

## Mounting Specifications

Valve Collar Length (A) .....	2.1" ±0.008 (54 ±0.2mm)
Valve Collar Diameter (B) .....	2.2" ±0.01 (56 ±0.3mm)
Valve Collar Mounting Bracket Clearance (C) .....	0.3" ±0.1 (8 ±2mm)
Recommended Mounting Area for the Valve Collar Mount (D) .....	1.5" ±0.1 (38 ±3mm)
Rear Collar Length (E) .....	3.7" ±0.008 (95 ±0.2mm)
Distance between Rear Collar Shoulder and Mount (F) .....	1.0" ±0.25 (26 ±7mm)
Recommended Mounting Area for the Rear Collar Mount (G) .....	1.5" ±0.3 (38 ±7mm)
Rear Collar Mounting Bracket Clearance (H) .....	1.1" ±0.1 (29 ±3mm)
Rear Collar Diameter (I) .....	2.0" ±0.003 (51 ±0.08mm)
Minimum Contact Bracket Width .....	1.1" (28mm)
Minimum Thread Engagement .....	1.1" (28mm)
Collar Mount Alignment Tolerance .....	±2°
Collar Mount Alignment Offset .....	0.5" (13mm)
Cylinder Mount Orientation .....	Horizontal ±2°

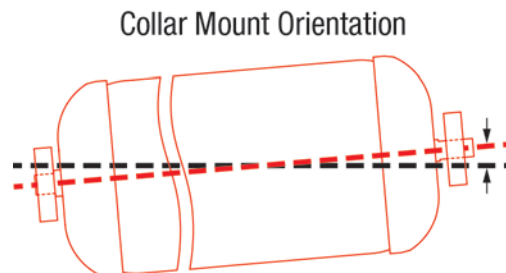
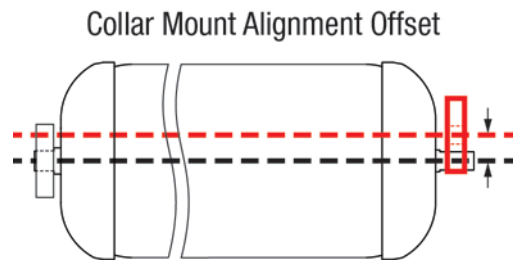
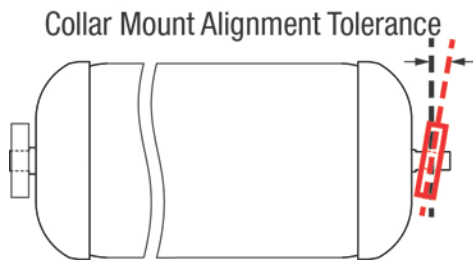
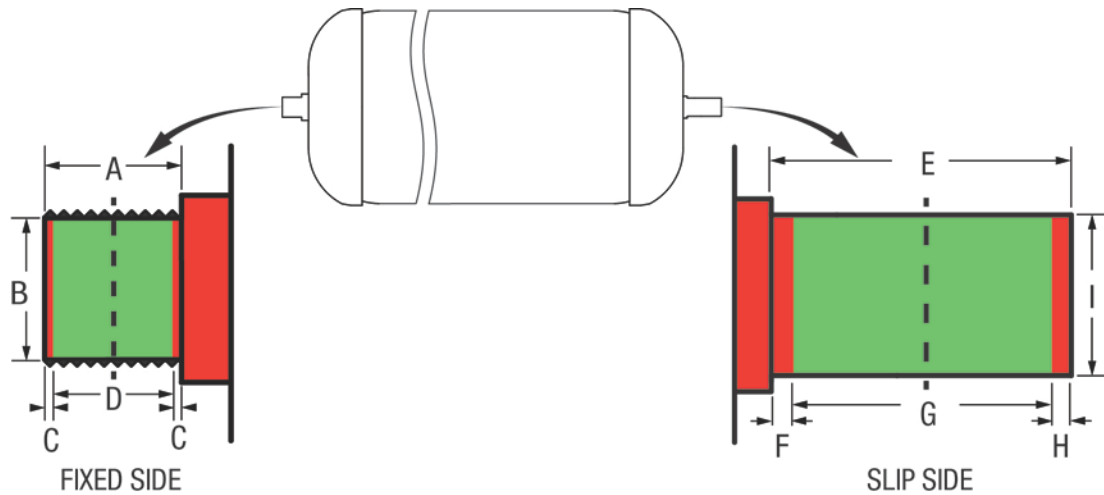

## Appendix A – Drawings

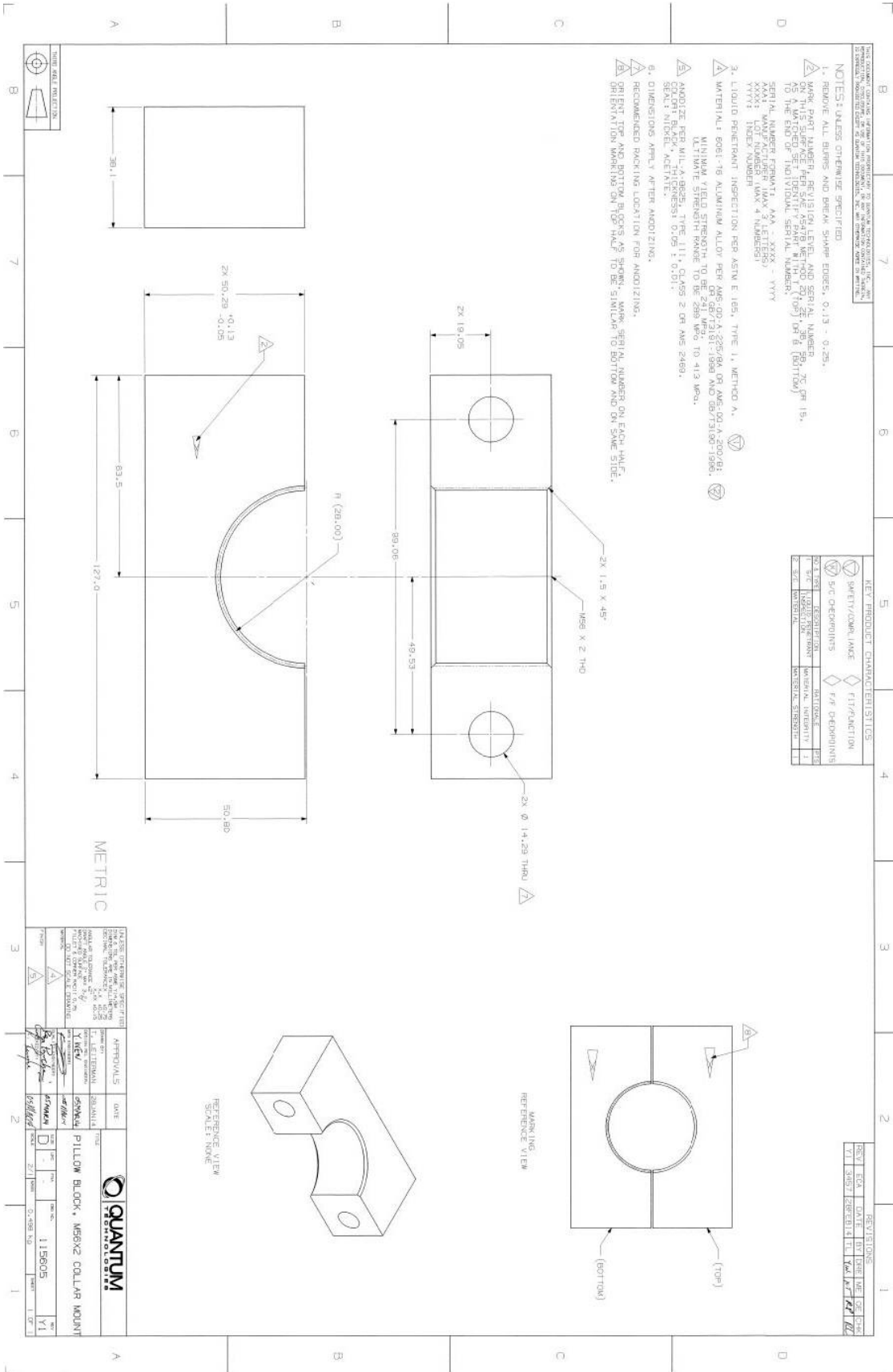

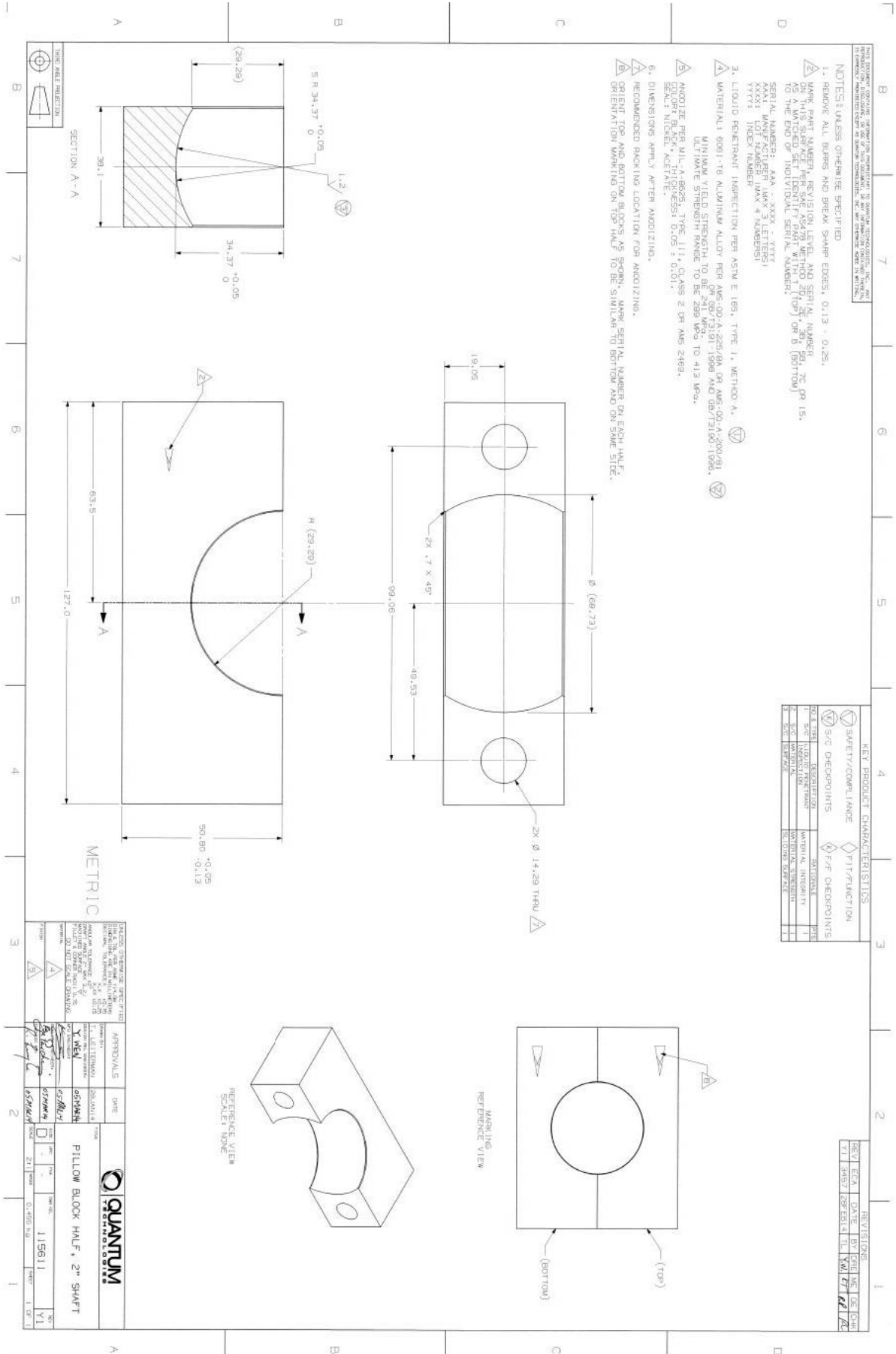

THIS DOCUMENT IS UNCLASSIFIED UNLESS INDICATED OTHERWISE. IT IS THE PROPERTY OF QUANTUM FUEL SYSTEMS, INC. AND IS NOT TO BE REPRODUCED OR TRANSMITTED IN ANY FORM OR BY ANY MEANS, ELECTRONIC OR MECHANICAL, INCLUDING PHOTOCOPYING, RECORDING, OR BY ANY INFORMATION STORAGE AND RETRIEVAL SYSTEM, WITHOUT PERMISSION IN WRITING.

NOTES: UNLESS OTHERWISE SPECIFIED

- REMOVE ALL BURRS AND BREAK SHARP EDGES, 0.13 ± 0.25.
- MARK PART NUMBER, REVISION LEVEL, AND SERIAL NUMBER ON THIS SURFACE PER SAE METHOD 3D, 2E, 3B, 3D, 7E OR 15, TO THE END OF INDIVIDUAL SERIAL NUMBER.
- SERIAL NUMBER: AAA-XXXX-YYYY  
 AAA: MANUFACTURER (MAX 3 LETTERS)  
 XXXX: LOT NUMBER (MAX 4 NUMBERS)  
 YYYY: YEAR (MAX 4 NUMBERS)
- LITIGIOUS RESTRICKT INSPECTION PER ASTM E 189, TYPE 1, METHOD A.
- MATERIAL: 6061-T6 ALUMINUM ALLOY PER AMS-90-A-225/9A OR AMS-90-A-200/9A. MINIMUM YIELD STRENGTH TO BE 291 MPa AND 427 MPa. ULTIMATE STRENGTH RANGE TO BE 289 MPa TO 413 MPa.
- ANODIZE PER MIL-A-8625, TYPE II, CLASS 2 OR AMS 2469.
- SCALE: UNLESS OTHERWISE SPECIFIED 0.05 ± 0.10.
- DIMENSIONS APPLY AFTER ANODIZING.
- RECOMMENDED MARKING LOCATION FOR ANODIZING.
- ORIENT TOP AND BOTTOM BLOCKS AS SHOWN. MARK SERIAL NUMBER ON EACH HALF.
- ORIENTATION MARKING ON TOP HALF TO BOTTOM AND ON SAME SIDE.

**KEY PRODUCT CHARACTERISTICS**

SAFETY/COMPLIANCE	✓	FUNCTIONALITY	✓
DESIGN/COMPLIANCE	✓	PERFORMANCE	✓
RELIABILITY	✓	QUALITY	✓
ENVIRONMENTAL	✓	LOGISTICS	✓
MANUFACTURABILITY	✓	TESTING	✓
INSTALLATION	✓	OPERATION	✓
MAINTENANCE	✓	REPAIR	✓
DISPOSAL	✓	RECYCLING	✓

REV	DATE	BY	CHK	APP
1	1/15/21	65784	1	65784

<b>QUANTUM FUEL SYSTEMS</b> 115611	
<b>APPROVALS</b> DESIGNED BY: 65784 DRAWN BY: 65784 CHECKED BY: 65784 ENGINEERED BY: 65784 MANUFACTURED BY: 65784	<b>DATE</b> 11/5/21
<b>PILLOW BLOCK HALF, 2nd SHAFT</b>	
PART NUMBER: 115611 REV: 1 DATE: 11/5/21 BY: 65784 CHK: 65784 APP: 65784	SCALE: 1:1

THIS DOCUMENT CONTAINS INFORMATION PROPRIETARY TO QUANTUM TECHNOLOGIES, INC. ANY REPRODUCTION, DISCLOSURE, OR USE OF THIS DOCUMENT OR ANY INFORMATION CONTAINED THEREIN IS EXPRESSLY PROHIBITED EXCEPT AS AUTHORIZED BY QUANTUM TECHNOLOGIES, INC. (ANY OTHERWISE AGREED IN WRITING)

**NOTES : UNLESS OTHERWISE SPECIFIED**

1. REMOVE ALL BURRS AND BREAK SHARP EDGES, 0.13 - 0.25.
2. MATERIAL: DELRIN OR ACETAL, COLOR WHITE.
3. IT IS ACCEPTABLE TO MACHINE, CAST, OR INJECTION MOLD THIS PART.

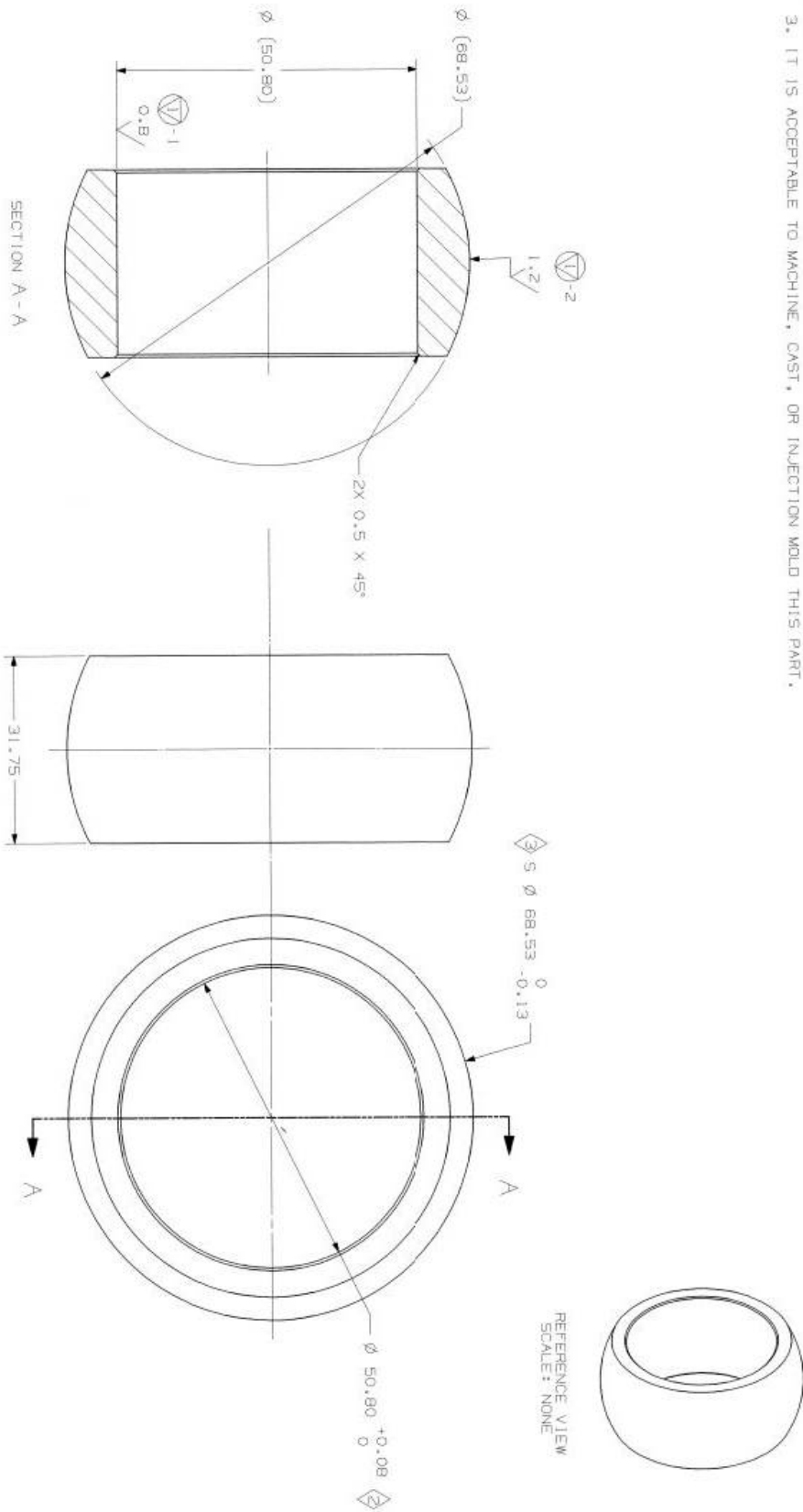

KEY PRODUCT CHARACTERISTICS			
SAFETY/COMPLIANCE	FIT/FUNCTION		
S/C CHECKPOINTS	F/F CHECKPOINTS		
NO. & TYPE	DESCRIPTION	NATIONALE	PTS
2	S/C SURFACE FINISH	SLIDING SURFACE	2
3	F/F TID	CLEARANCE	1
	F/F 100	CLEARANCE	1

METRIC

REV	DATE	BY	CHK
1	28 JAN 14	YV	RP
2	28 FEB 14	YV	RP

REV	DATE	BY	CHK
1	28 JAN 14	YV	RP
2	28 FEB 14	YV	RP

APPROVALS

DATE

TITLE

BEARING, SPHERICAL, 2" SHAFT

115613

SCALE: 2/1

0.054 (kg)

SHEET 1 OF 1